

Culligan®

Hi-Flo 9 Filter ^{CE}

20 - 54

TECHNICAL SHEET



General

Hi-Flo 9 Culligan Filters are designed to respond to industrial proposes.

They are controlled by diaphragm valves opening and closing singly to direct the water flow during service and backwash steps. A timer activates a pilot valve which opens and closes the diaphragm valves.

Backwash is automatically started by an electronic programmer, at any time of the day or night, on any day of the week. It can also be started manually and the filter will automatically resume service at the end of backwash step.

All models, up to 48", feature the hydraulic harness in Noryl PVC. Starting from 60" the harness is in cast iron, with epoxy coating.

The filter tanks are internally protected by a controlled thickness of epoxy paint, and externally coated with a neutral synthetic enamel

Culligan Hi-Flo and TWIN Filters cover any requirements for mechanical filtration and for chemico-physical filtration obtained by means of filtering layers.

The processes employed in Hi-Flo and TWIN Filters are:

- **Filtr-Cleer (UF)**, to remove any kind of turbidity from the water, and small quantities of Iron and Manganese; the Minerals utilized are anthracite and silica, chemically inert and of unlimited life.
- **Cullar (UR)**, to remove undesirable odour, taste and colours, as well as excess Chlorine. Cullar is a granular form of activated carbon.

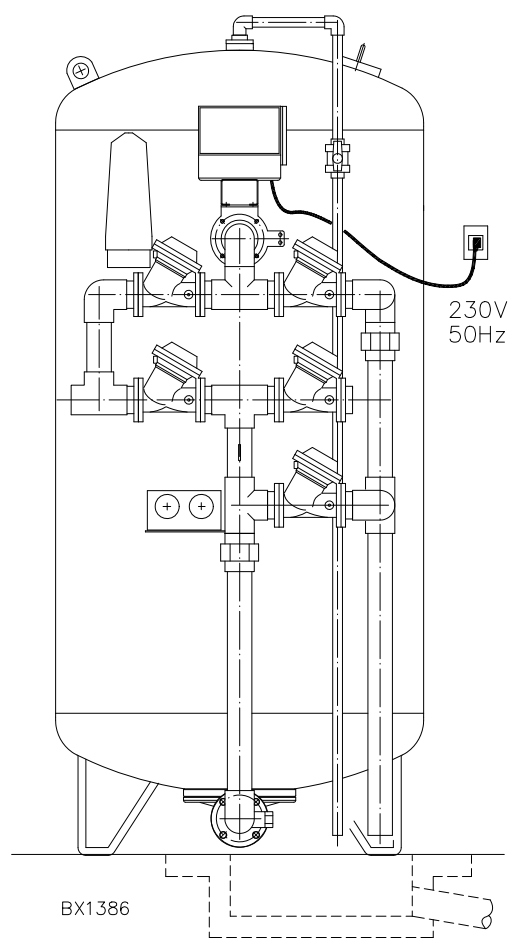

- **Cullneu (UU)**, to neutralize acid water. Cullneu is a granular mineral of Calcium carbonate that dissolves in proportion to the neutralized acidity.
- **Super Iron (UFP)**, for selective Iron and Manganese removal UFP Mineral has a strong catalising effect, enhanced by the injection of a proper chemical.

M003-78 – Rev. 02 – 07/2007

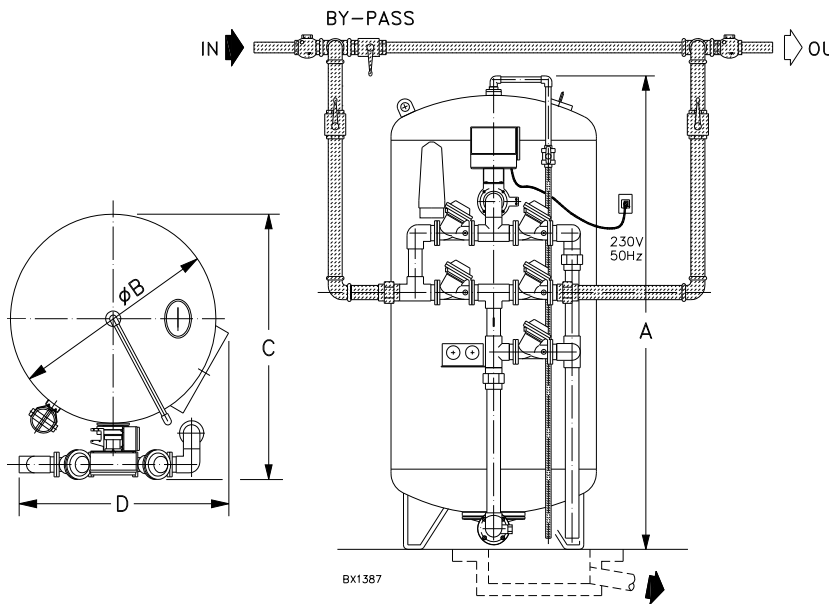

These dimensions may vary ± 2%.

Model	A mm	B mm	C mm	D mm
UF 20	1950	500	735	710
UR 20				
UU 20				
UFP 20				
UF 24	1985	600	835	710
UR 24				
UU 24				
UFP 24				
UF 30	2050	750	985	765
UR 30				
UU 30				
UFP 30				
UF 36	2131	950	1215	975
UR 36				
UU 36				
UFP 36				
UF 48	2235	1200	1436	1258
UR 48			1465	
UU 48			1436	
UFP 48			1436	
UF 54	2367	1400	1632	1432
UR 54			1626	
UU 54			1632	
UFP 54			1632	

TECHNICAL SPECIFICATIONS

HI-FLO 9 Model	Piping IN/OUT dia. * "	FLOW RATES						Max. Pressure Loss ** max bar	Operating Pressure		Weight #	
		Service (SR)		Backwash (BW)		Rinse (CR)			min. bar	max bar	Operating kg	Shipping kg
		min. m ³ /h	max m ³ /h	gpm	m ³ /h	gpm	m ³ /h					
FILTR-CLEER (Turbidity)												
UF 20	1 ½	2	4,7	35	7,9	20	4,5	1	1,5	7	770	470
UF 24	1 ½	2,8	6,7	48	10,9	30	6,8	1	1,5	7	1100	680
UF 30	1 ½	4,5	11	70	15,9	48	10,9	1	1,5	7	1700	1030
UF 36	2	7	17	120	27,3	70	15,9	1	1,5	7	2980	1910
UF 48 •	2 ½ x 2	11	27	180	40,9	120	27,3	1	1,5	7	4490	2790
UF 54	2 ½	18	37	245	56	162	37	1	1,5	7	4800	3100
CULLAR (Taste - Odour - Colour)												
UR 20	1 ½	1,2	4,7	15	3,4	11	2,5	0,3	1,5	7	760	460
UR 24	1 ½	2,8	6,7	20	4,5	15	3,4	0,3	1,5	7	1030	600
UR 30	1 ½	4,5	11	30	6,8	25	5,7	0,3	1,5	7	1600	930
UR 36	2	7	17	48	10,9	40	9,1	0,3	1,5	7	2720	1650
UR 48	2	11	27	80	18,2	60	13,6	0,3	1,5	7	3500	2410
UR 54	2 ½	18	37	110	25	81,5	18,5	0,3	1,5	7	4250	2950
CULLNEU (Acidity)												
UU 20	1 ½	-	3	35	7,9	20	4,5	0,5	1,5	7	830	530
UU 24	1 ½	-	4,5	48	10,9	30	6,8	0,5	1,5	7	1150	725
UU 30	1 ½	-	7	70	15,9	48	10,9	0,5	1,5	7	1780	1110
UU 36	2	-	11	120	27,3	70	15,9	0,5	1,5	7	3030	1955
UU 48 •	2 ½ x 2	-	18	180	40,9	120	27,3	0,5	1,5	7	4785	3085
UU 54 •	2 ½ x 2	-	25	245	56	162	37	0,5	1,5	7	5100	3250
SUPER IRON (Iron and Manganese)												
UFP 20	1 ½	1,5	3	35	7,9	20	4,5	0,5	1,5	7	770	470
UFP 24	1 ½	2,2	4,5	48	10,9	30	6,8	0,5	1,5	7	1100	680
UFP 30	1 ½	3,5	7	70	15,9	48	10,9	0,5	1,5	7	1700	1030
UFP 36	2	5,5	11	120	27,3	70	15,9	0,5	1,5	7	2980	1910
UFP 48 •	2 ½ x 2	9	18	180	40,9	120	27,3	0,5	1,5	7	4490	2790
UFP 54	2 ½	12	25	245	56	162	37	0,5	1,5	7	4800	3100

* The diameters indicated refer to filter pipeworks. They do not apply to connections to pipe network.

** The figure indicates pressure drop with dirty filter (caused by filtering layers) and obtained by deducting the figure indicated on "OUT" pressure gauge from the figure indicated on "IN" pressure gauge.

Weights are approximate.

• Only for Models UF-UU-UFP 48, during backwash with operating pressure equal to 3 bar remove the BW flow control; with operating pressure more than 3 bar the BW flow control must not be removed.

Notes: - Power Supply: 230-110-24V - 50-60Hz
 - Installed Power: 10 W
 - Temperature: 5 to 40°C.

Culligan reserves the right to change or modify the stated specifications or dimensions